



AEGIS CHECKWEIGHER

Designed for Food & Packaging Industries

The Aegis checkweigher has been designed with the customer in mind by delivering low cost of ownership and simple maintenance. The Aegis is supplied in full retail compliance configuration and has, we believe, eliminated the persistent problems encountered during operation and servicing, over many years in the industry.



Features include:

- Designed and built in the UK
- Washdown IP66 rated
- Constructed to minimise bug traps but facilitate easy and effective washdown
- Multilevel password protection
- Supermarket Compliance Specifications
- 10" colour monitor and touchscreen user interface
- Power save option
- Enhanced USB security key option

The system combines a robust weigh table, conveyor and control system.

The modular concept means the Aegis checkweigher can be easily converted into a combination unit making production layout changes easy.

Weigh table length can be varied 'in-situ' between 350mm and 500mm without affecting the overall length of the conveyor. This flexibility allows the machine to accommodate different sizes of products reducing the need for additional capital expenditure for new product launches.

The machine handling can be changed relatively simply. This feature allows the machine to adapt with future changes to factory configuration and reduces the need for new machinery purchases.

The running gear is accessed quickly through drop down guarding, which permits quick yet extensive access for clean down and maintenance activity and the tables have been designed to allow quick changes of transport belts, drive motors and rollers.

The machine has a power save option that saves energy and reduces wear on running gear components.



AEGIS CHECKWEIGHER

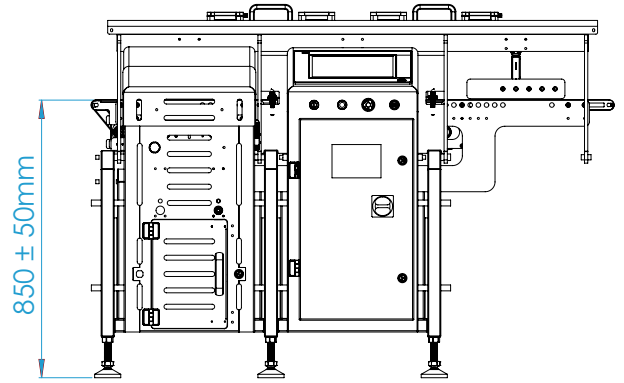
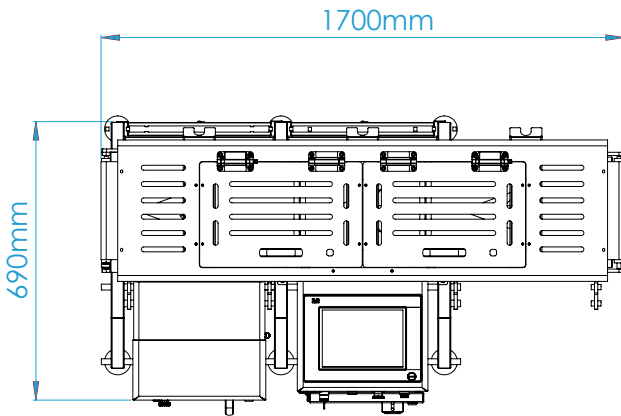

Specification

Weight capacity:	2000g
Weight range:	50g to 2000g
Belt speed:	20 to 60m/min
Min weight conveyor:	200mm (W) x 350mm (L)
Max weight conveyor:	300mm (W) x 500mm (L)
Height:	850mm +- 50mm
Length:	1700mm
Width:	690mm
Belt type:	PU
Belt width:	300mm
Failsafe	Full retail compliance config
Reject:	Air blast or overhead pusher
Electrical:	220-240V single phase 16 Amp 50-60Hz
Warranty:	1 year

Applications

- Bakery
- Cereal
- Confectionery
- Dairy
- Fish
- Packaged Products
- Fruit & Vegetables
- Meat & Poultry
- Nuts & Grains
- Snack Foods
- Dried Fruits

Options

- Ethernet
- Data Collection
- Spares Kit
- Extended Warranty
- Production Support Package

☎ 01252 510565
 ✉ sales@ukinspectionssystem.com
 🌐 www.ukinspectionssystem.com

Head Office:
 Unit 15, Hercules Way
 Farnborough Aerospace Centre
 Farnborough
 Hampshire, GU14 6UU

Manufacturing:
 Units 5 & 6, Elan Court
 Norris Way
 Rushden
 Northants, NN10 6BP



Registered in England: Number 06932748